

General Description

The ACP2701 is a high power, constant frequency, current mode PWM, inductor based, step-up converter. The converter operates at high 1.5MHz frequency allowing the use of tiny, low cost and low height inductors and capacitors. A constant frequency internally compensated current mode PWM architecture results in low, predictable output noise that is easy to filter. Low ESR ceramic capacitors can be used at the output, further reducing noise to millivolt level. The high voltage switch on the ACP2701 is rated at 36V, making the devices ideal for boost converters up to 29V.

The ACP2701 has built-in soft start function to reduce inrush current when start, and has built-in overvoltage protection (OVP) to allow the device goes into shutdown mode when the output voltage exceeds the OVP threshold of 29V.

The ACP2701 is available in SOT23-5

Features

- Wide Input Voltage Range : 2.6V to 16V
- Feedback Voltage:1.25V
- Switching Current Limit: 500mA
- Internal Power N-MOSFET Switch
- High 1.5MHz Operating Frequency
- Internal Soft Start
- 29V Over Voltage Protection
- Small SOT23-5 Packages
- RoHS Compliant and Halogen Free

Application

- STN/TFT LCD Bias Supply
- Wireless RF Amplifier Bias Supply
- OLED Driver
- DC/DC Converter

Typical Application

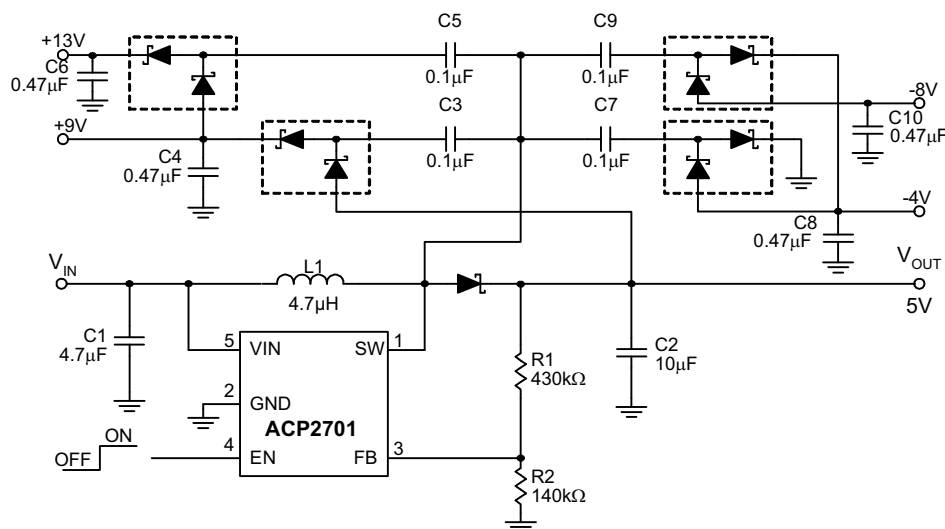

Pin Configuration and Description

Pin Configuration	Pin Description		
	Pin#	Symbol	Function
<p>TOP VIEW</p> <p>SOT23-5</p>	1	SW	Power Switch Output. Connect the inductor and the blocking Schottky diode to SW.
	2	GND	Ground
	3	FB	Feedback input pin. The reference voltage at this pin is 1.25V.
	4	EN	Enable pin. A high input at EN enables the device and a low input disables the devices. When not used, connect EN to the input source for automatic startup.
	5	IN	Input Supply Pin. Must be locally bypassed.

Ordering and Marking Information

Standard Part NO.	VFB	Package	Packing	Min. Quantity	RoHS
ACP2701-125DTRAL	1.25V	SOT23-5	Tape&Reel	3000PCS	Pb Free

Remark: for marking information, please see sample or contact our sales for more detail information.

Function Block

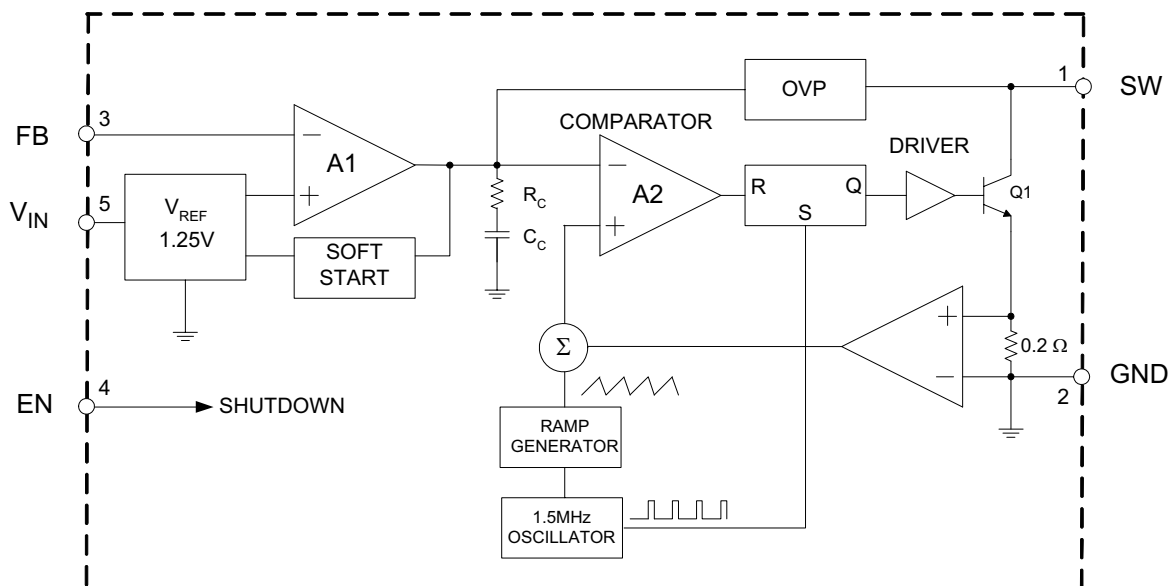

**Absolute Maximum Ratings**

Parameter	Symbol	Value	Unit
Input Voltage	V _{IN}	20	V
SW Voltage		38	V
FB Voltage		5	V
Enable Voltage		16	V
Thermal Resistance (Junction to Atmosphere, no Heat sink)	R _{θJA}	265	°C/W
Operating Junction Temperature		150	°C
Storage Temperature Range	T _{STG}	-65 to 150	°C
Lead Temperature (Soldering, 10sec)	T _{LEAD}	260	°C
ESD (Machine Model)		250	V
ESD (Human Body Model)		2000	V
Operating Temperature	T _{OP}	-40 to 85	85

Electrical Characteristics

(V_{IN}=3.0V, V_{EN}=3.0V, T_A=25°C, unless otherwise specified.)

Parameter	Symbol	Conditions	Min	Typ	Max	Unit
Minimum Operating Voltage			2.6			V
Maximum Operating Voltage					16	V
Feedback Voltage	V _{FB}	V _{IN} =5V, V _{OUT} =24V, I _{OUT} =30mA	1.17	1.25	1.33	V
FB Pin Bias Current		V _{FB} =1.25V	10	45	100	nA
Supply Current	I _{CC}	V _{SHDN} = V _{FB} = V _{IN} , No switching		2.5	3.5	mA
Supply Current	I _Q	V _{SHDN} = 0V, V _{FB} = 0V		0.1	1.0	μA
Switching Frequency	f		1.1	1.5	1.9	MHz
Maximum Duty Cycle	D _{MAX}		85	90		%
Switching Current Limit		Duty Cycle=80%		500		mA
Switch V _{CESAT}	V _{CESAT}	I _{SW} =250mA		300		mV
Switch Leakage Current		V _{SW} =5V		0.01	5	μA
SHDN Voltage High (ON)	V _{TH}		1.5			V
SHDN Voltage Low (OFF)	V _{TL}				0.4	
SHDN Pin Bias Current				55		μA
OVP Voltage Threshold	V _{OVP}			29		V
Soft-Start Time				550		μS

Typical Operating Characteristics

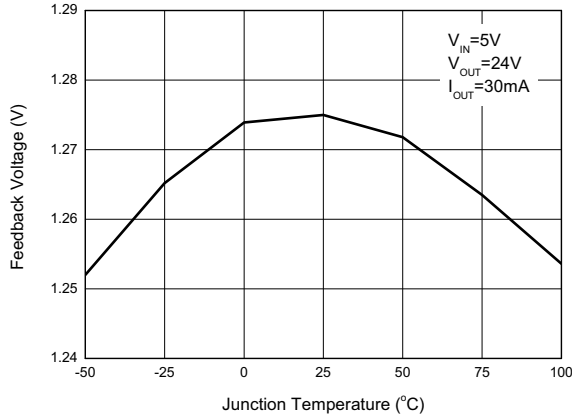

Feedback Voltage vs. Junction Temperature

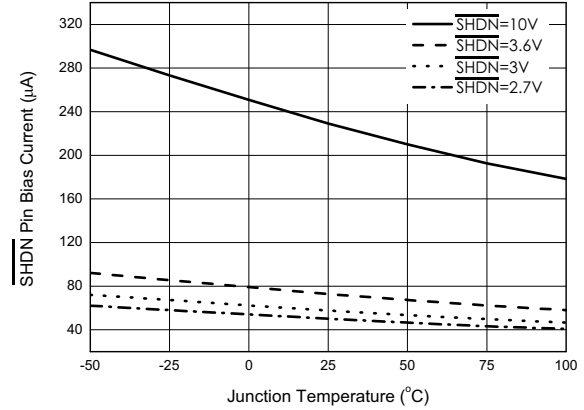

SHDN Pin Bias Current vs. Junction

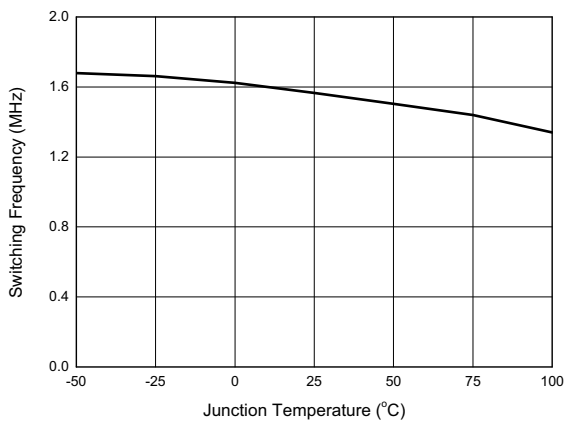

Switching Frequency vs. Junction Temperature

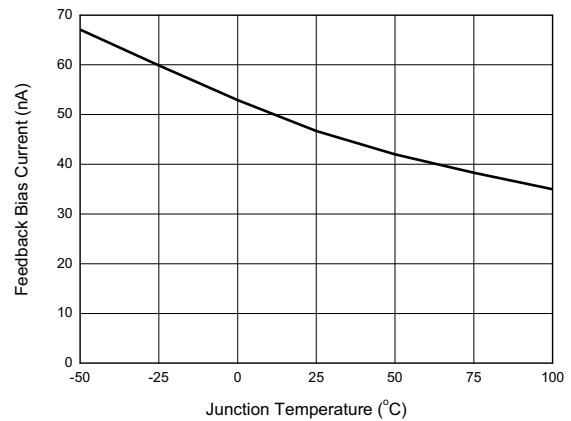

Feedback Bias Current vs. Junction Temperature

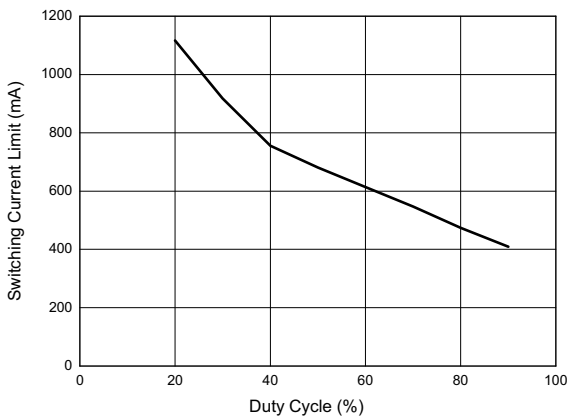

Switching Current Limit vs. Duty Cycle

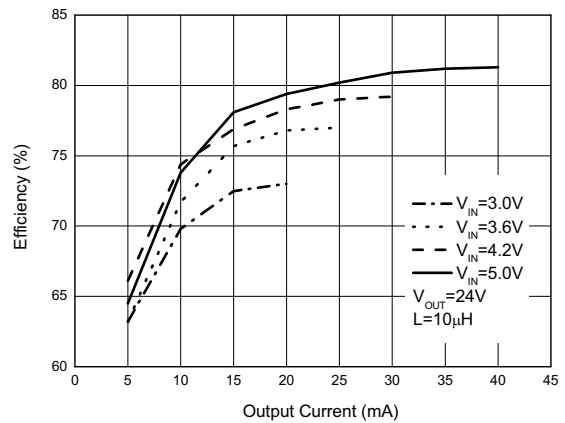

Efficiency vs. Output Current

Application Information

● Operation

The ACP2701 uses a constant frequency, peak current mode boost regulator architecture to regulate the output voltage. The operation of the ACP2701 can be understood by referring to the simplified block diagram shown above. At the start of each oscillator cycle, the control logic turns on the power switch Q1. The signal at the non-inverting input of the PWM comparator is proportional to the switch current, summed together with a portion of the oscillator ramp. When this signal reaches the level set by the output of error amplifier, the PWM comparator resets the latch in the control logic and turns off the power switch. In this manner, error amplifier sets the correct peak current level to keep the output voltage in regulation. If the feedback voltage starts to drop, the output of the error amplifier increases. This results in more current to flow through Q1, hence increasing the power delivered to the output.

● Inductor Selection

For most of application of ACP2701, it is recommended to use an inductor of 22uH. Although small size is one of the major factors in selecting an inductor, the smaller and thinner inductors give higher core losses at 1.25MHz and DRC, resulting in lower efficiencies.

● Capacitor Selection

The small size of ceramic capacitors makes them ideal for ACP2701 applications. X5R and X7R types are recommended because they retain their capacitance over wider voltage and temperature ranges than other types such as Y5V or Z5U. A 4.7F input capacitor and a 4.7F output capacitor are sufficient for most ACP2701 applications. The compensation capacitor C3 is selected as 22p in the typical application.

● Diodes Selection

Schottky diodes, with their low forward voltage drop and fast reverse recovery, are the ideal choices for ACP2701 applications. The forward voltage drop of a Schottky diode represents the conduction losses in the diode, while the diode capacitance (CT or CD) represents the switching losses. For diode selection, both forward voltage drop and diode capacitance need to be considered. Schottky diodes with higher current ratings usually have lower forward voltage drop and larger diode capacitance, which can cause significant switching losses at the 1.5MHz switching frequency of the ACP2701.

● Resistor Selection

The output voltage is controlled by the feedback resistor. The feedback reference is 1.25V. The output voltage is $1.25 \times (1 + R2/R1)$. In order to have accurate output voltage, precision resistors are preferred (1% is recommended). The formula and table for R1 and R2 selection are shown below: $V_{OUT} = 1.25 \times (1 + R2/R1)$
It is recommended to select 10KΩ to 500KΩ resistance value for R1 for lower quiescent leakage on FB to ground.

● Board Layout Consideration

As with all switching regulators, careful attention must be paid to the PCB board layout and component placement. To maximize efficiency, switch rise and fall times are made as short as possible. To prevent electromagnetic interference (EMI) problems, proper layout of the high frequency switching path is essential. The voltage signal of the SW pin has sharp rise and fall edges. Minimize the length and area of all traces connected to the SW pin and always use a ground plane under the switching regulator to minimize interplane coupling. In addition, the ground connection for the feedback resistor R1 should be tied directly to the GND pin and not shared with any other component, ensuring a clean, noise-free connection.

Package Information

SOT23-5

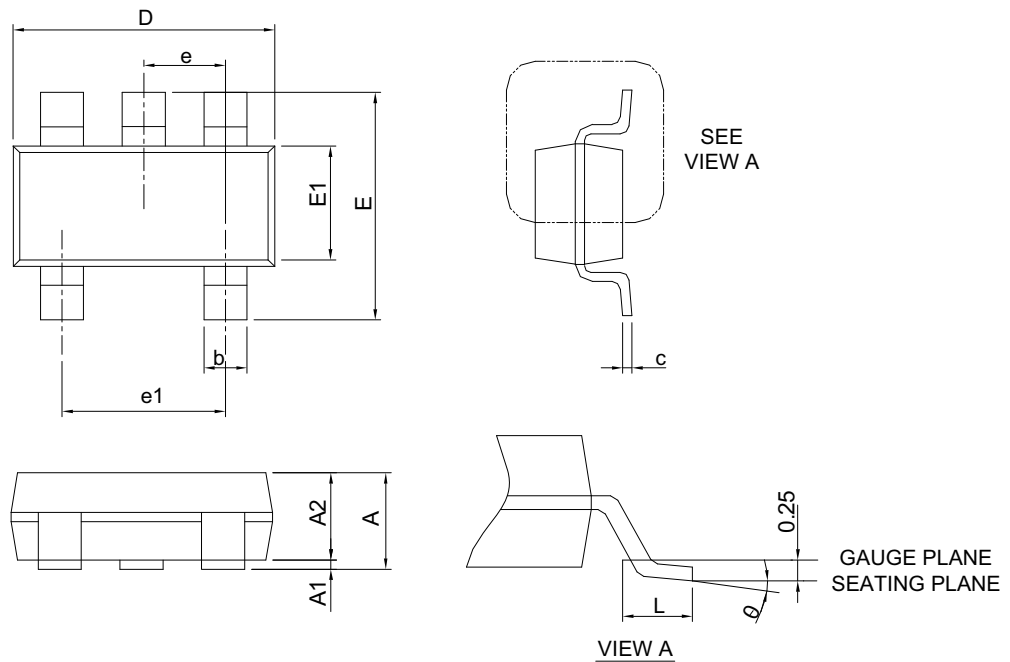

SYMBOL	SOT-23-5			
	MILLIMETERS		INCHES	
	MIN.	MAX.	MIN.	MAX.
A		1.45		0.057
A1	0.00	0.15	0.000	0.006
A2	0.90	1.30	0.035	0.051
b	0.30	0.50	0.012	0.020
c	0.08	0.22	0.003	0.009
D	2.70	3.10	0.106	0.122
E	2.60	3.00	0.102	0.118
E1	1.40	1.80	0.055	0.071
e	0.95 BSC		0.037 BSC	
e1	1.90 BSC		0.075 BSC	
L	0.30	0.60	0.012	0.024
θ	0°	8°	0°	8°

Note : 1. Follow JEDEC TO-178 AA.

2. Dimension D and E1 do not include mold flash, protrusions or gate burrs. Mold flash, protrusion or gate burrs shall not exceed 10 mil per side.